

# PRE-INSTALLATION READINESS

*for instalation shower enclosure, shower enclosure with light **LIGHT** and shower enclosure with steam **STEAM***

## WHITEWATER



**RAVAK**<sup>®</sup>

Whitewater shower enclosure is delivered unassembled. The glass panels, the aluminium columns and the shower tray with its panel and small accessories (also with the top-cover for the shower enclosure STEAM) come each in separate packages.

The product is intended for installation into a fully finished bathroom with complete floor and wall tiling. The bathroom walls must be able to withstand 4,5 kN tension from the wall-plugs. While the conventional brick or concrete walls adhere to this norm, walls built from other specific materials require special mounting fittings of appropriate construction and loading requirements.

Height of the bathroom must be a minimum of 2,5 m, and space required for installation of the product is approximately 2 x 2 m. For the space requirements of the Whitewater shower enclosure, see the following pictures. Total height of the shower enclosure is 2300 mm, and total height of the shower box is 2400 mm.

Water supply points and waste pipe must be prepared at the place of shower enclosure installation. For LIGHT and STEAM connections to the electric power supply must also be prepared -as stated in the following requirements.

To apply a warranty, it is necessary that the product be installed by a professional company trained for the assembly of this product.

### Whitewater shower enclosure or shower enclosure with light - LIGHT

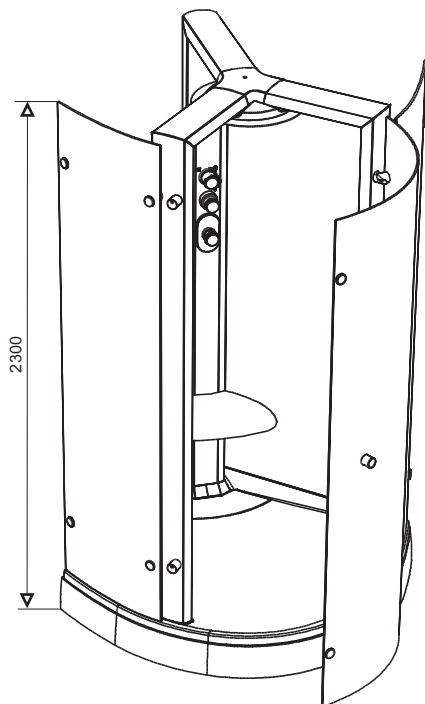

### Whitewater STEAM

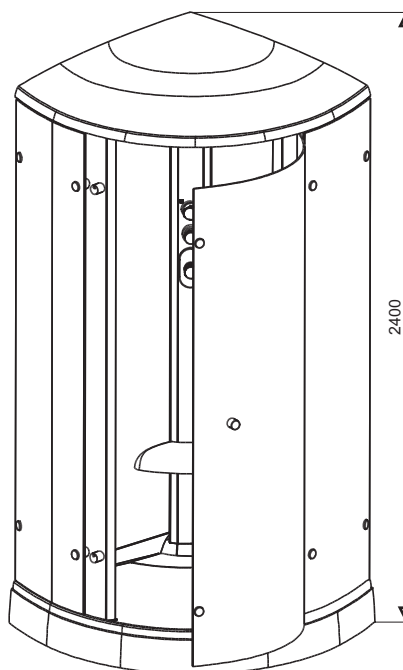

#### Requirements of the water supply:

|  |            |
|--|------------|
| Supply water pressure (both hot and cold)    | 2-5 bar    |
| Approximate water requirement for the cabin: |            |
| Steam bath 1 cycle (15 minutes)              | 7 litres   |
| Side showers                                 | 11 l/ min  |
| Hand shower (normal/ jet)                    | 8/9 l/ min |
| Head shower                                  | 12 l/ min  |

To ensure proper functioning of the product, the water system needs to provide both the sufficient water pressure and water volume.

#### Hot water supply (recommendation):

For maximum comfort and sufficient bathing time in the shower box, you need to provide a hot water supply of adequate capacity.

**Storage reservoir** should have capacity of at least 100 litres, with its thermostat set at the maximum.

**Instantaneous heater** can be used only if it adheres to the above mentioned water amount and water pressure requirements. Its energy output should not be less than 20,000 kcal/ hour.

**Combined reservoir** with continual water heating and a capacity of 100 litres fulfils all the above stated requirements.

**Central source of hot water** is the ideal system for supplying hot water to the whole household.

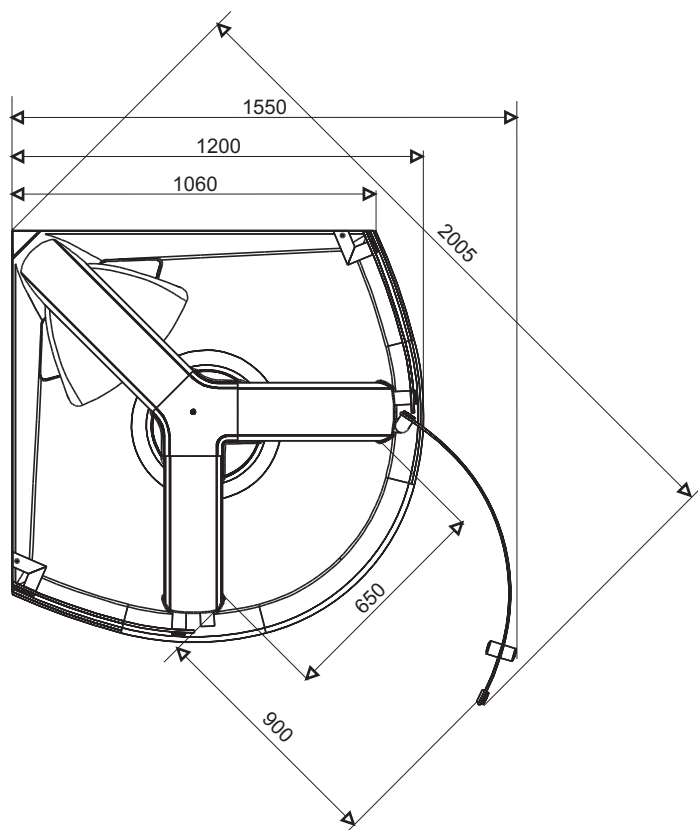

**Mounting positions:**

The shower enclosure should be mounted on the bathroom walls with wall plugs - therefore it is necessary to drill mounting holes into the walls - see the red marked positions in the picture. Connections to the water and electricity source must be an appropriate distance from the mounting positions!

**Hot and cold water inlet:**

Build the hot and cold water inlets at one of the positions under the shower tray - marked green in the picture. End the outlet pipes with 1/2" threads to enable their connection after removing the panel. The box will be connected to the water supplies with flexible hoses. The optimal water pressure is 3 bar for both the hot and cold water. Prior to connecting the shower box to the source of electric power, the water supplies must be tested for leaks and whole system rince out.

**Household outflow system**

A 50 mm waste-pipe needs to be built in the floor in the position marked yellow in the picture, maximum 70 mm above the floor. We recommend you to use a flexible hose or flexible pipes for connecting the piping outlet to the 40 mm outlet of the shower tray siphon.

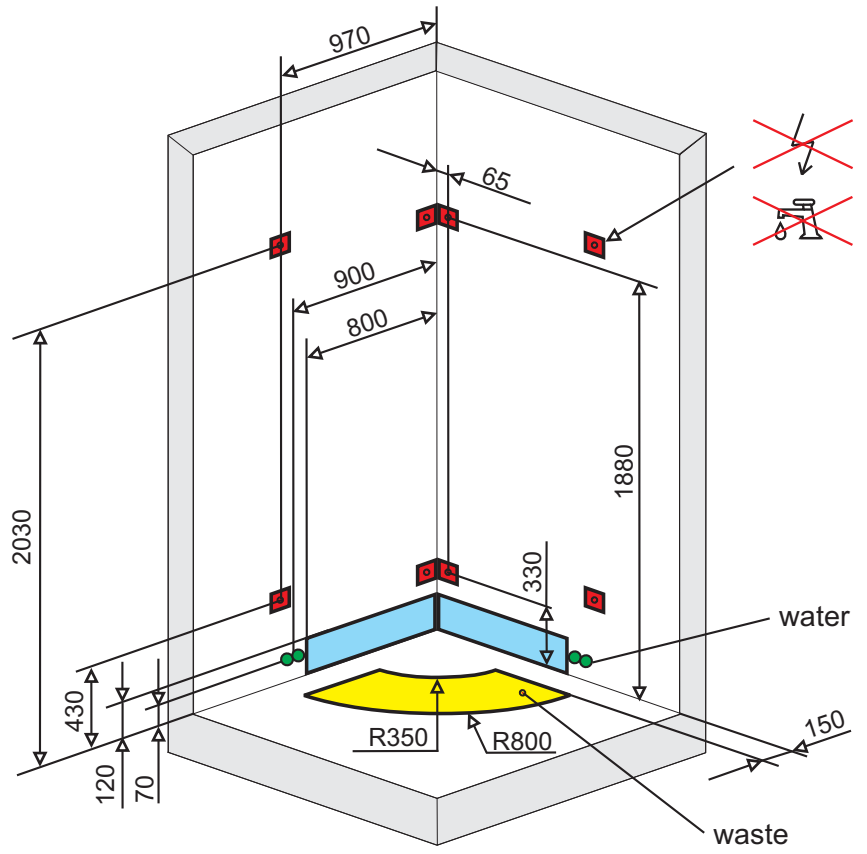

**WASTE OUTLET**

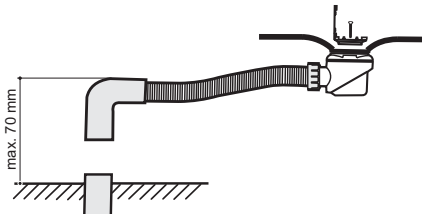

**Electric power inlet (for the shower enclosure with overhead light and steam)**

Position of the inlet is indicated with blue colour. For connecting the shower box/ enclosure, lead out a cable approx. 3 m long from the wall.

**Electric installation (for the shower enclosure with overhead light and steam)**

If a connector for the HydroMassage shower enclosure is not a part of the whole project, it is compulsory to adhere to the following conditions for connecting:

1. The electricity intake line must (according to the law norm CSN 33 2130 par.2.4.1) serve for the HM enclosure connection only. It has to be equipped with a double pole isolator (the CSN 33 2000-5-537 law norm) and a 20A (10 A) single pole circuit breaker (for the shower enclosure with overhead light, a 10 A circuit breaker is sufficient) combined with a current protector of up to 30mA operating residual current (CSN 33 20000-7-701)
2. The intake cables must be dimensioned for the steam system power drain (4,4 kW) and for the line voltage drop (adequate to the inlet cable length) -minimum CYKY 3x2,5 mm<sup>2</sup>. The outlet built under the shower tray should be situated 100 mm above the floor with sufficient reserve of loose cable (minimally 3 m).
3. In the secondary electricity supply box, the PEN cable must be divided into a PE and N cable -thus the TN-C system will be converted into the TN-S (this relates to the older types of electro-installations). In case this conversion is not possible due to technical parameters, it needs to be performed in the secondary distribution board (located close to the hydromassage enclosure) that is equipped with a double pole isolator, a 20A single pole circuit breaker combined with a current protector of up to 30mA operating residual current. Setting and location of the electro-installation features must follow the appropriate law norm - CSN 33 20000-7-701.
4. In the room where the box/ enclosure will be installed, use Cu cables of minimum 4 mm<sup>2</sup> cross section to perform the local connecting of the box/ enclosure at the place of its installation. (CSN 33 2000-4-41/1996 tab.41 NNa)
5. An installation report must be written for the completed electricity intake connection of the hydromassage box/ enclosure (CSN 33 1500, CSN 33 2000-6-61). Only on the basis of this report and of conditions observance control and confirmation, will our service engineer connect the product, test the functioning of the whole system, and consequently confirm the warranty certificate.

**Safe manipulation with electro-installation**

Only a person/ company holding a valid license is permitted to work with the electro-installation (see the valid law norm 50/78 par.6)

**WASTE OUTLET AND WATER SUPPLY**

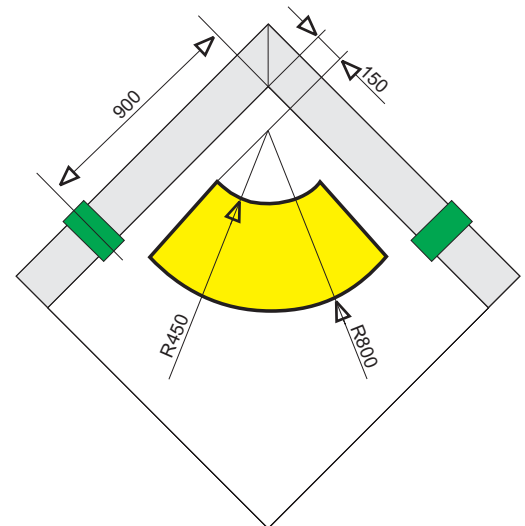

**GREEN INDICATES** - the position of G 1/2" hot and cold water inlets.

**YELLOW INDICATES** - the position of the waste outlet.

**RED INDICATES** - the position of the fixing holes (that need to be drilled in the walls).

**ATTENTION!** No supply pipes or cables permitted in the red areas!

**BLUE INDICATES** - the position of the electric power supply.

**RAVAK®**

**RAVAK a.s.**, Obecnická 285, 261 01 Příbram I  
tel.: +420 318 427 200, 318 427 111 fax: +420 318 427 269  
e-mail: [smith@ravak.cz](mailto:smith@ravak.cz), [www.ravak.com](http://www.ravak.com)

The manufacturer reserves the right to change the price, technical parameters or other facts without a prior notice and shall bear no responsibility for the printing errors.